

# Performance Modeling

## Introduction

1

## Steps in Performance Modeling

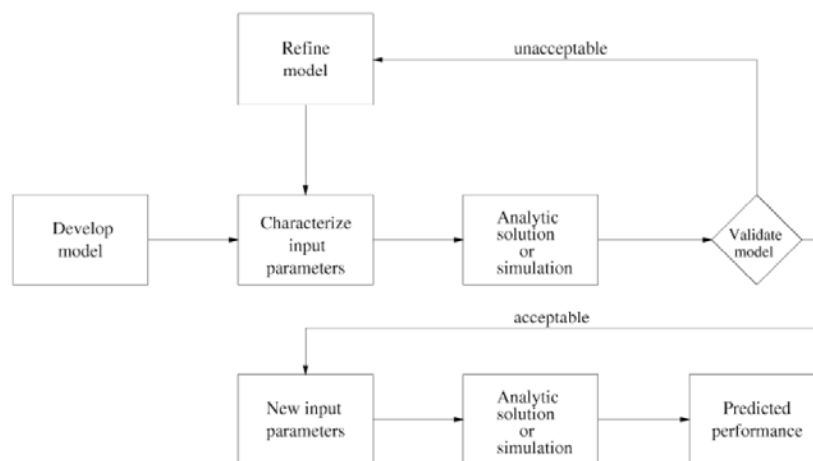

2

## Model Development

- Need to have a good understanding of how the system works
  - if possible, consult with those who have detailed knowledge of the system
  - Seek expert opinion on system components that need to be carefully modeled, e.g., bottleneck
  - Where appropriate, use modeling studies on similar systems as reference

3

## Model Development

- Understand the objective of the performance study
- Identify the key entities and their attributes
- Select the type of queuing models to be used
  - e.g., single server queue, single service facility with multiple servers, queuing network
- For those entities that correspond to resources, identify their resource management schemes
  - e.g., queuing disciplines, buffer management schemes

4

## Model Development

- Identify the input parameters and the performance measures
  - input parameters may include some of the attributes (e.g., interarrival time) and/or resource management schemes
  - selection of input parameters and performance measures should be consistent with the objective of the study

5

## Example 1 –Channel Scheduling

- In a communication networks, messages sent from source to destination are organized as “flows”
- At a router, the routing algorithm recognizes flows when determining the outgoing channel for each incoming message
- There is finite buffer space for each outgoing channel

6

## Example 1 –Channel Scheduling

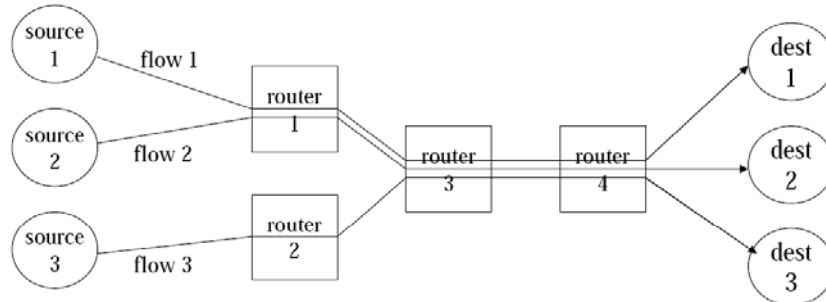

7

## Objective 1

- Suppose objective is to compare the delay performance at a given channel for different combinations of channel scheduling algorithms and buffer allocation schemes, under different load levels

8

## Model Development

- Focus on the channel from router 1 to router 32 flows (flows 1 and 2) are transmitted over this channel
- Assumptions
  - no error in message transmissions
  - a message is lost if buffer space at outgoing channel is not available
  - control messages are not included in the model

9

## Entities and Attributes

### Entities

channel  
buffer  
message belonging to flow 1  
message belonging to flow 2  
system

### Attributes

capacity  
size  
length  
length  
interarrival time of flow 1  
interarrival time of flow 2

10

## Queueing Model

- Type of model -single server queue
- Server, which represents the communication channel
- Two classes of customers, one for each flow
- Finite waiting room, which models the finite buffer space

11

## Resource Management Scheme

- Channel scheduling algorithms
  - first come, first served (FCFS)
  - fair queuing -a separate queue is maintained for each flow, and the two queues are serviced in a round robin fashion
- Buffer allocation scheme
  - complete sharing -buffers are allocated to messages in a FCFS manner, no distinction is made on the basis of flow ID
  - sharing with minimum allocation -each flow is guaranteed a minimum number of buffers; the remainder is allocated in a FCFS manner

12

## Single Server Queue Model

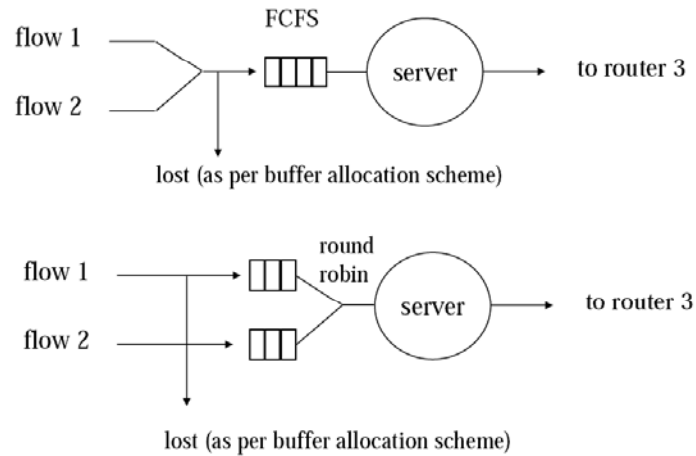

13

## Input Parameters and Performance Measures

### ○ Input parameters

- interarrival time of flow  $i$  messages,  $i = 1, 2$
- message length of flow  $i$ ,  $i = 1, 2$
- channel capacity
- buffer size
- channel scheduling algorithm
- buffer allocation strategy

### ○ Performance measure

- delay (waiting time + transmission time) experienced by flow  $i$  messages,  $i = 1, 2$

14

## Objective 2

- Suppose objective is to compare the end-to-end delay (within the network) for different combinations of channel scheduling algorithms and buffer allocation schemes, under different load levels

15

## Entities and Attributes

### Entities

channel 1 (router 1 to 3)  
channel 2 (router 2 to 3)  
channel 3 (router 3 to 4)  
buffer at channel  $i$ ,  $i = 1, 2, 3$   
message belonging to flow  $j$ ,  
 $j = 1, 2, 3$   
system

### Attributes

capacity  
capacity  
capacity  
size  
length  
routing frequency  
interarrival time of flow  $j$ ,  
 $j = 1, 2, 3$

16

# Queuing Model

- Type of model -queuing network
- Servers, each of them representing an outgoing channel (note: processing at routers is assumed to be negligible)
- Three classes of customers, one for each flow
- Finite waiting room at each server, which models the finite buffer space

17

# Queueing Network Model

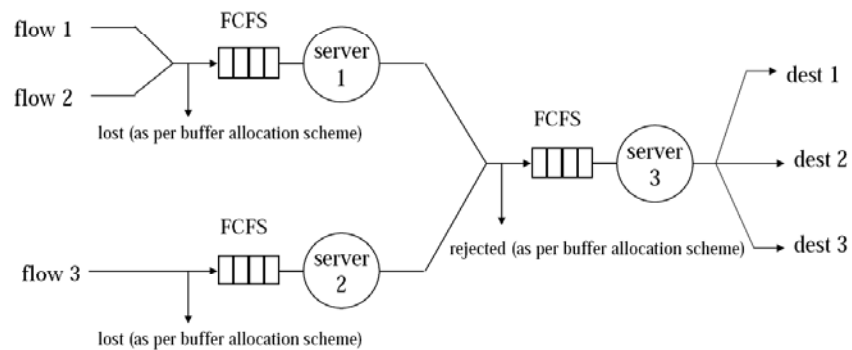

18

## Example 2 –Computer Lab

- KAUST IT has installed  $m$  workstations in a lab
- Students may freely use these workstations for their school work
- It is anticipated that the number of students will increase in the near future
- The objective is to develop a queuing model that can be used to determine the required number of workstations

19

## Model Assumptions

- Infinite population model -number of potential customers (i.e., students) is large
- An arriving customer who finds all workstations in use will
  - leave immediately with probability  $p$ , or
  - wait for an available workstation with probability  $1-p$
- The queuing discipline is not well-defined
  - FCFS is a reasonable assumption (if one is interested in mean waiting time)

20

## Entities and Attributes

### Entities

service facility

workstation

customer

system

### Attributes

number of workstations

--

service time

$p$  = prob. of leaving immediately if all workstations are busy at time of arrival

customer interarrival time

21

## Queueing Model

- Type of model -single service facility with multiple servers (number of servers is  $m$ )
- Each server represents a workstation
- One class of customers -a customer can be served by any of the  $m$  servers
- FCFS discipline
- An arriving customer will leave immediately (with prob.  $p$ ) if all servers are busy

22

## Single Service Facility with Multiple Servers Model

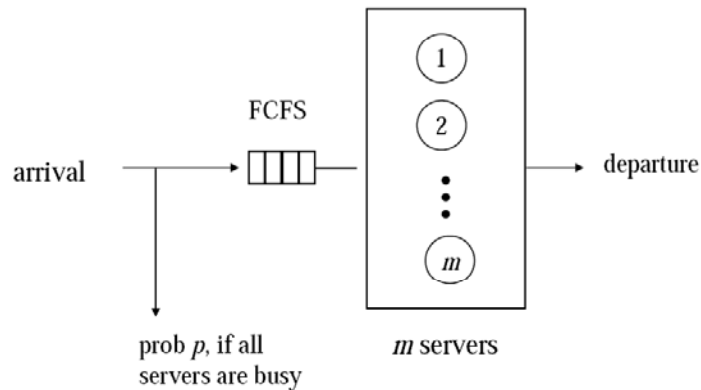

23

## Input Parameters and Performance Measures

- Input parameters
  - customer interarrival time
  - service time
  - number of servers,  $m$
  - Probability,  $p$
- Performance measures
  - probability that an arriving customer finds all servers busy
  - mean number of busy servers

24